



OVER

Automatizms for swinging doors

PATENT PENDING

I N S T A L L A T I O N I N S T R U C T I O N

OVER

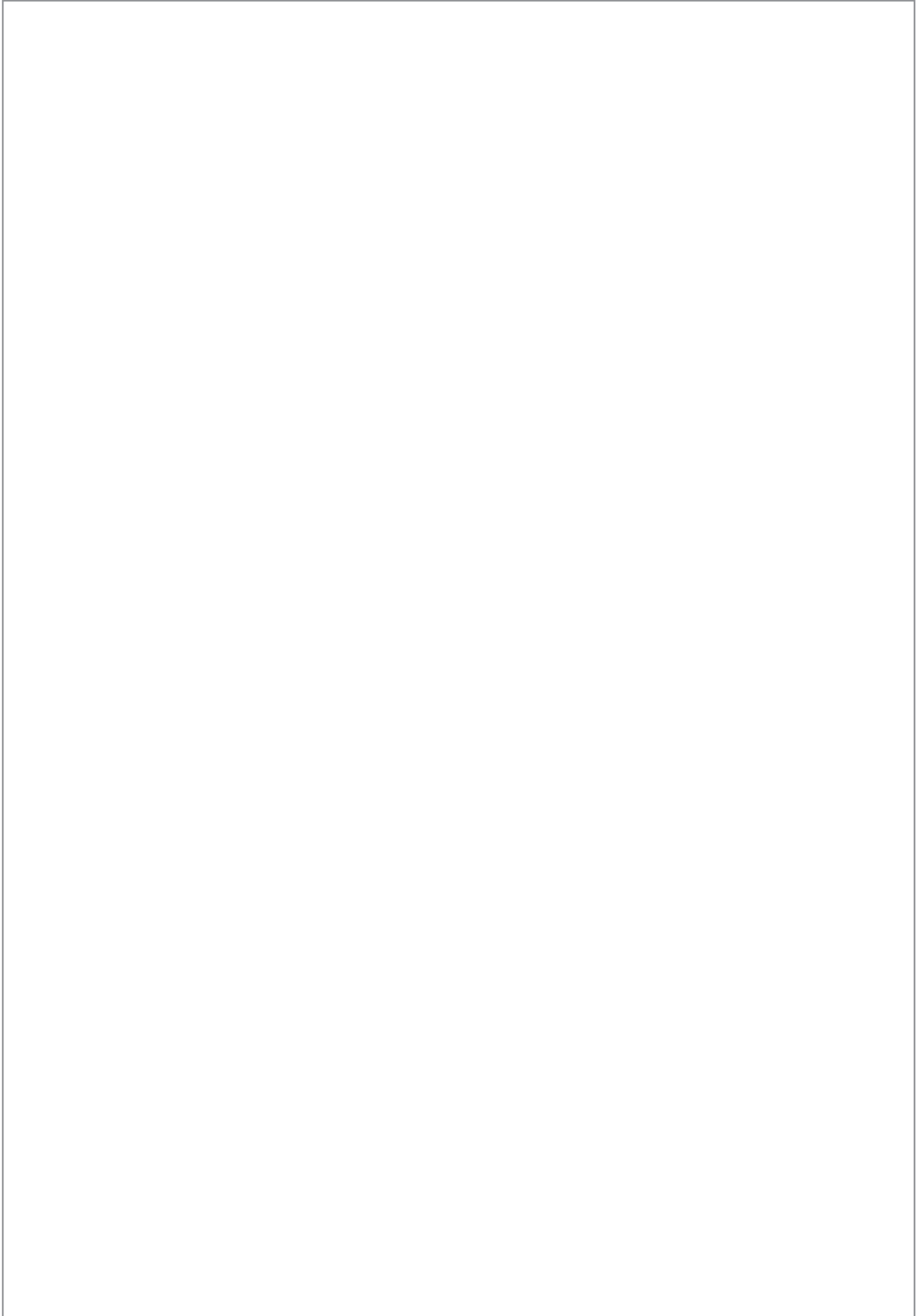

Index

Technical specifications	pag.	5
Automatism installation preparation.....	pag.	5
Automatism description	pag.	5
Sizes and dimensions	pag.	6
Dimensions of the fixing holes and cables opening	pag.	6
Automatism assembly	pag.	7
Adjustment of the stop	pag.	11
Battery connections	pag.	11
Final operations	pag.	11
Power connections	pag.	11
Electrical connections.....	pag.	11
Number wing selection.....	pag.	12
Single wing Multislave selection	pag.	12
Double wing Master - Slave selection	pag.	12
“Low Power” mode selection	pag.	12
First input mode selection	pag.	13
Antipanic mode selection	pag.	13
Electric Lock selection	pag.	13
Logic right / left opening sense	pag.	13
Type of arm selection	pag.	14
OVER electronic board.....	pag.	14
Connections	pag.	14
Led functions	pag.	16
Jumpers	pag.	16
Setting parameter adjustment	pag.	16
Start up - Operating logic	pag.	17
Error Message Table.....	pag.	18
Double OVER connection and use	pag.	19
Inter lock connection and use	pag.	19
Delivery modality	pag.	19

APRRIMATIC reserves the right to change the technical specifications of the products, even without notice.

Thank you for choosing this product. For best automatism performance, Aprimatic recommends you carefully read and follow the installation and use instructions found in this manual. Installation of this automatism must only be performed by the professionally qualified personnel for whom this manual is addressed. Any errors during installation may be harmful to people or things. Packaging material (wood, plastic, cardboard, etc.) should not be scattered in the environment or left within the reach of children as potential sources of danger. Every installation phase must be performed in accordance with the regulations in force and following Good Technique standards. Before beginning installation make sure that the product is integral and has not been damaged during transportation or by poor storage conditions. Before installing the product make sure that each architectural and structural element of the entrance (girder fastening surfaces, casings, guide, etc.) is appropriate and sufficiently robust to be automated. Conduct a careful risk analysis and make suitable modifications to eliminate conveyance, crushing, cutting and hazardous areas in general. Do not install the product in environments where gas, steam or inflammable fumes are present. The manufacturer is not liable for any neglect of "good technique" or specific regulations in the construction of the casing to be motorised and any collapse of the same. All automatic entrance safety and protection devices (photocells, active sensors, etc.) must be installed in accordance with the regulations and directives in force, with the completed risk analysis, system type, use, traffic, forces and inertia in play. Pay careful attention to area where the following may occur: crushing, cutting, conveyance and any other type of hazard in general applying, if necessary suitable indications. Indicate the motorised door identification information on every installation. Make sure that the upstream electrical system is correctly dimensioned and has all the opportune protections (circuit breakers and fuses). Only use original spare parts in maintenance and repairs. Do not tamper or alter devices in the automatism and all the safety devices in the control panel for any reason. The manufacturer is not liable if parts within the automatism are altered or tampered with or if safety devices other than those indicated by the manufacturer are used in the system. The automatism installer must provide the automatic entrance manager with the use manual and all the information required for correct use in automatic and manual modes (even for electronic locking) and in the event of emergency.

Pay careful attention to the messages in this manual that are marked with the hazard symbol. They can either be warnings aimed at avoided potential equipment damage or specific signals of potential hazard to the installer and others. This device was designed to automate swinging doors. Any other use is considered contrary to the use foreseen by the manufacturer who therefore shall not be held liable.

Machine directive

The installer who motorised a door becomes the automatic door machine manufacturer according to directive 98/37/CE and must:

- Arrange the Technical Booklet with the documents indicated in attachment V of the Machine Directive and keep them for at least 10 years.
- Draft the CE declaration of conformity according to attachment II-A of the machine directive and provide the use with a copy.
- Apply the CE markings on the motorised door according to point 1.7.3 of attachment I of the machine directive.

Machine conformity directive

(Directive 98/37 CE, Attachment II, part B)

Manufacturer: APRIMATIC S.p.A.
Address: V.L.da Vinci 414 - 40059
 Villafontana di Medicina - BO

Declares that the product OVER

- Is built to be incorporated in a machine or to be assembled with other machinery to build a machine considered by Directive 98/37 CE, as modified;
- Therefore it is not fully compliant to the dispositions of this Directive since it is not yet assembled with other components.
- It is in conformity to the following other CE directives: 89/336/CEE Electro-magnetic compatibility and further modifications 2006/95CE Low Voltage and further modifications and also declares that the machinery cannot be used until the machine it is incorporated in or is a component of has been identified and its conformity to Directive 98/37 CE conditions and national legislation declared.

Villafontana di Medicina, 09/09/2007

Dott. Alessandro Minelli
 (Administrator)

Technical specifications

Power supply	230V ac 50 Hz
Nominal power	60 W
Nominal motor torque	35 Nm
External device power	12Vdc – 2,5W
Emergency battery	12 V 1.3 Ah
Max opening angle	100°
Wing maximum weight	80 Kg
Wing dimensions	700÷1200 mm
Working temperature	Internal cross-piece from 0°C a +50°C
Anti-crushing	Automatic traction restriction in the presence of obstacles
Weight	6,7 kg
Service	Intensive

Automatism installation preparation

The automatism is prepared to work in different accessory and peripheral configurations. According to the selected configuration, arrange the cables necessary for wiring all the peripherals. Fig.1 shows an example of complete installation including:

- A. Entry Radar
- B. Active safety sensor
- C. Safety closing device
- D. Logic selection selector
- E. Opening button at exit

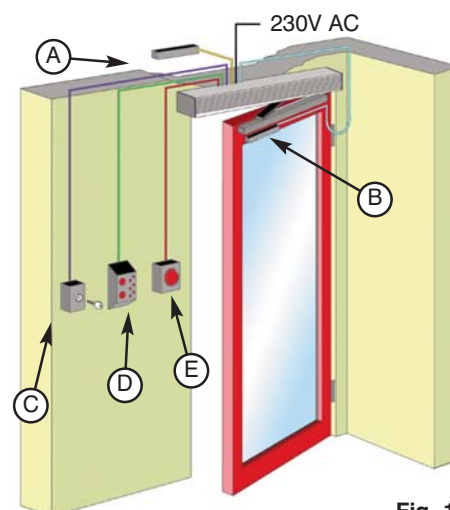

Fig. 1

Automatism description

The OVER automatism (Fig.2) is essentially made up of:

- A. Steel fastening base
- B. Plastic cover
- C. Gear motor unit
- D. Electronic control panel
- E. Transformer
- F. Emergency battery (12V 1,3Ah)
- G. Encoder unit
- H. Switch

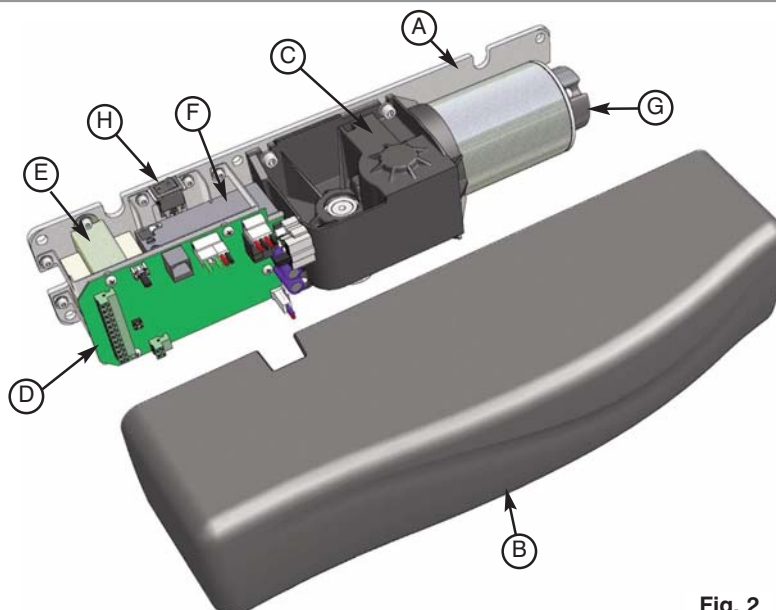

Fig. 2

Sizes and dimension

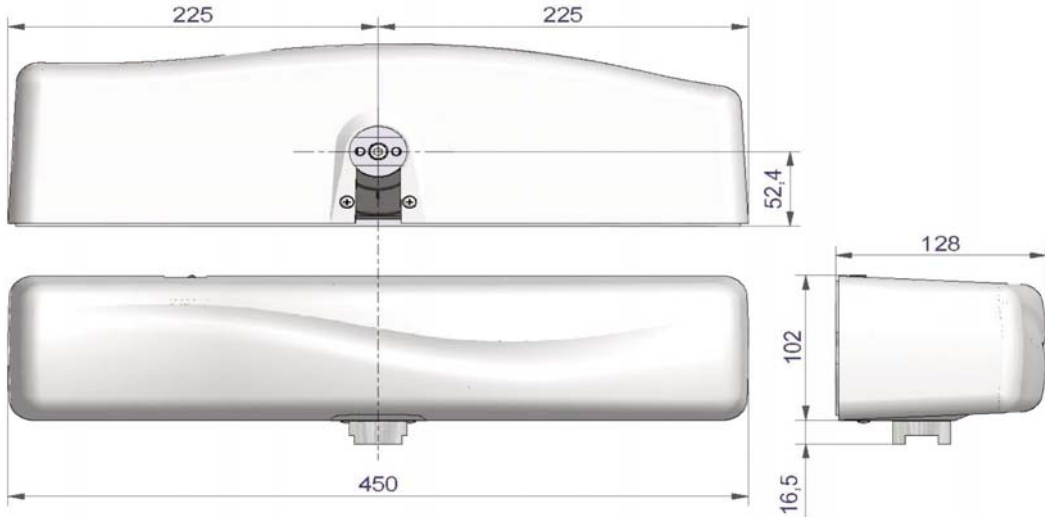

Fig. 3

Dimension of the fixing holes and cables opening

OVER standard

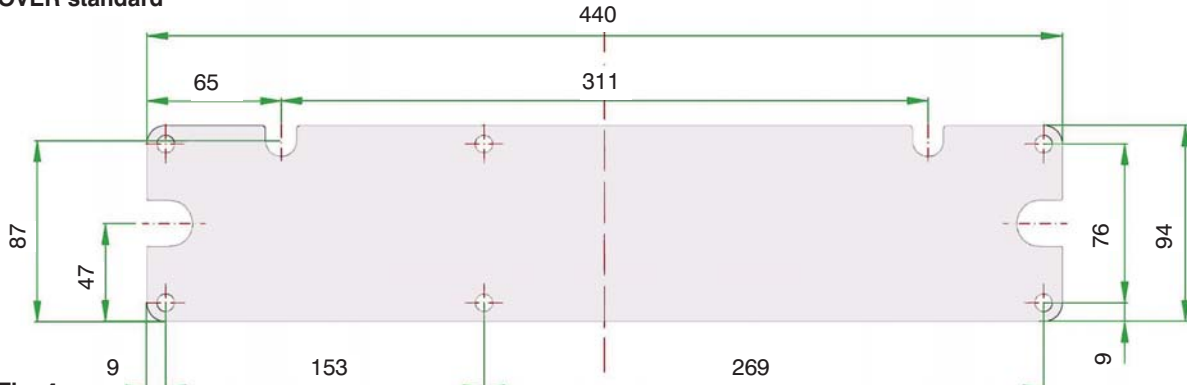

Fig. 4

⚠ Use the appropriate drilling template included with the product to make easier the installation.

⚠ In case of double OVER provide to the predisposition of the connection (cables passing) between the two operators

Adapter plate (optional)

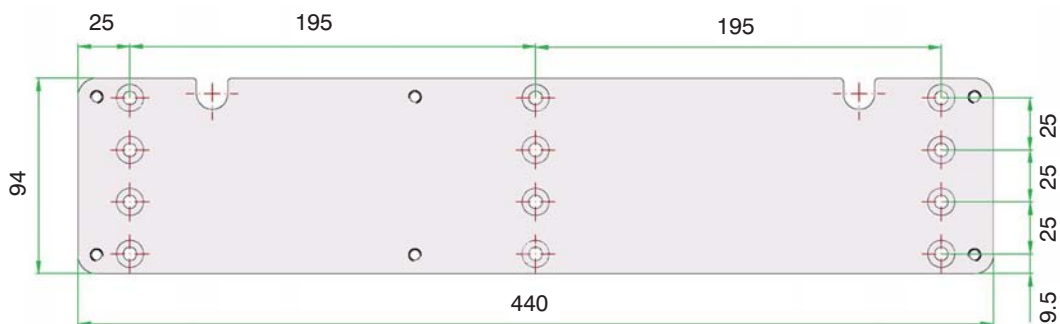

Fig. 5

Automatism assembly

⚠ WARNING : Before proceeding with the installation, remove the 2 cardboard components positioned underneath the motor body.

Positioning dimensions (rigid pull arm)

The rigid pull arm is used when the automatism is installed on the swing side of the door.

⚠ WARNING : For a correct positioning, always use the main axis of the wing hinges and the operation axis of the gearmotor as a reference, as shown in Fig.5.

OVER fastening diagram 1 left-hand opening wing Rigid Pull Arm

For right-hand opening wings (anticlockwise direction), the assembly of the automatism perfectly mirrors the left-hand opening assembly.

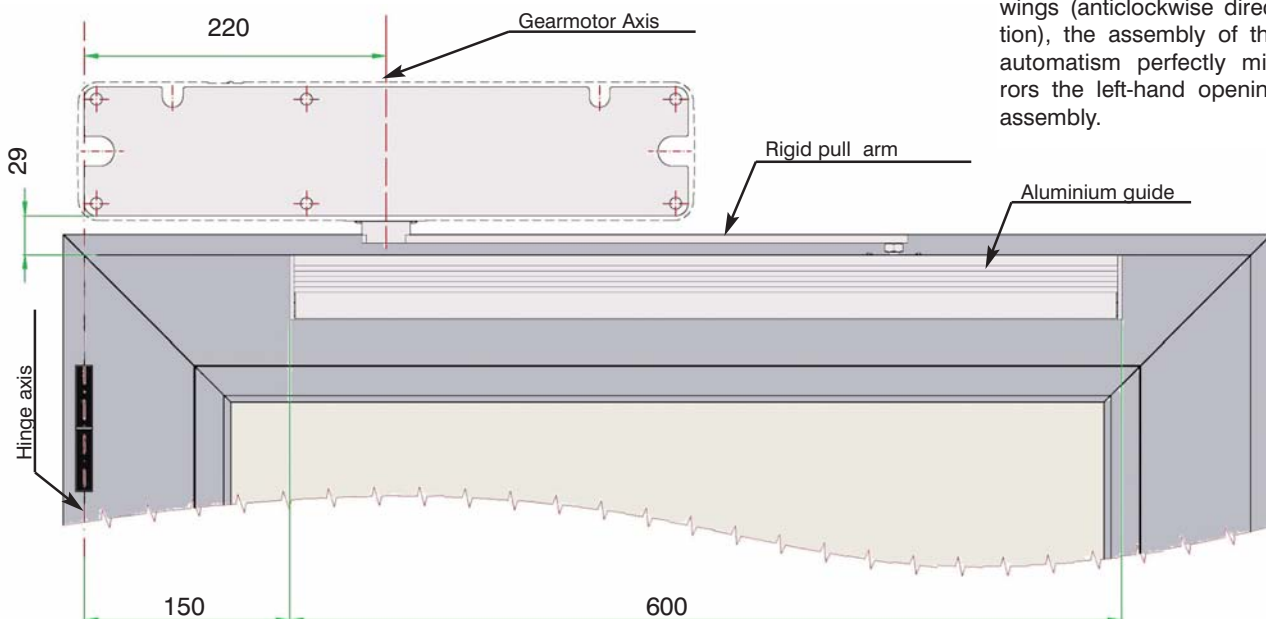

Fig. 5

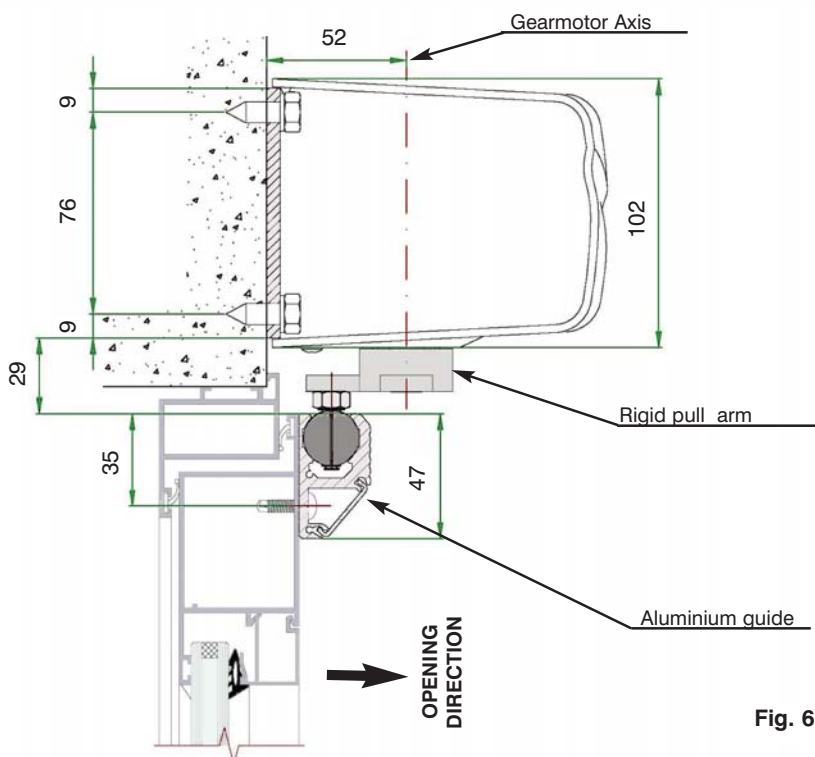

Fig. 6

⚠ WARNING : The final tightening of the screws must be performed only after having checked that the vertical positioning of the automatism guarantees a good parallelism between the hinge axis and the gearmotor axis. For this purpose, the rigid pull arm and relative guide must be installed, check that the pin coupling the arm to the cylindrical slide is not strained during operation.

An error in the position of the automatism may, in fact, cause the pin of the rigid arm to oscillate with respect to the cylindrical slide to a degree beyond the allowed tolerance, with consequent damage to one of the automatism parts.

Positioning dimensions (articulated push arm)

The articulated push arm is used when the automatism is installed on the approach side of the door (the side opposite the swing side).

! WARNING : For a correct positioning, always use the main axis of the wing hinges and the operation axis of the gearmotor as a reference, as shown in Fig.7.

OVER fastening diagram 1 left-hand opening wing Articulated push arm

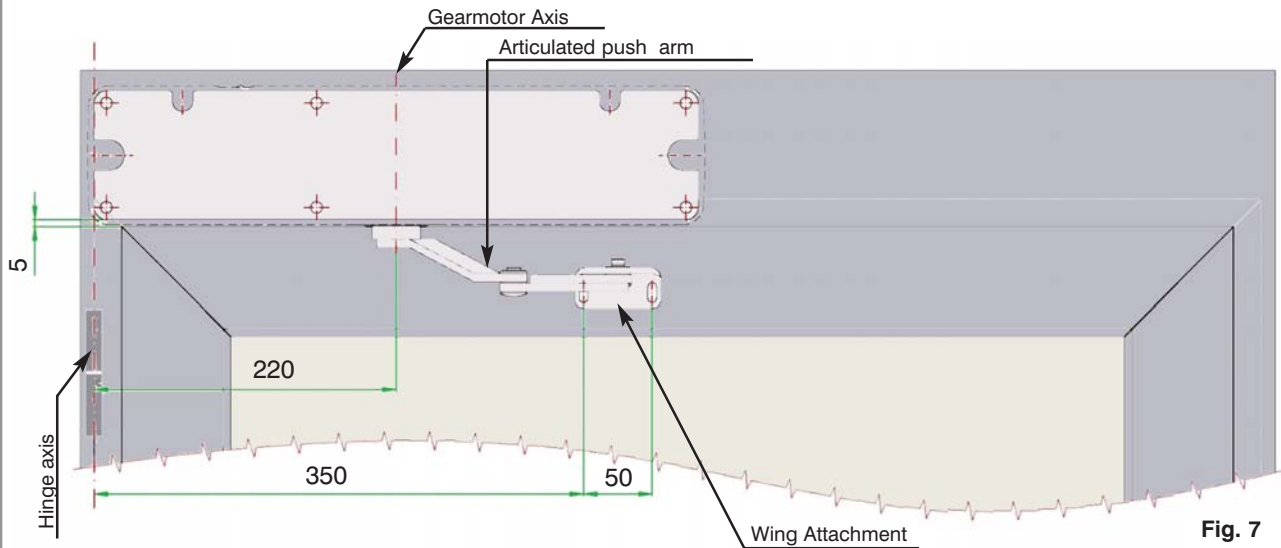

Fig. 7

For right-hand opening wings (anticlockwise direction), the assembly of the automatism perfectly mirrors the left-hand opening assembly.

! WARNING : The final tightening of the screws must be performed only after having checked that the positioning of the automatism and articulated arm guarantees smooth rotation of the same under the door frame (Fig.8).

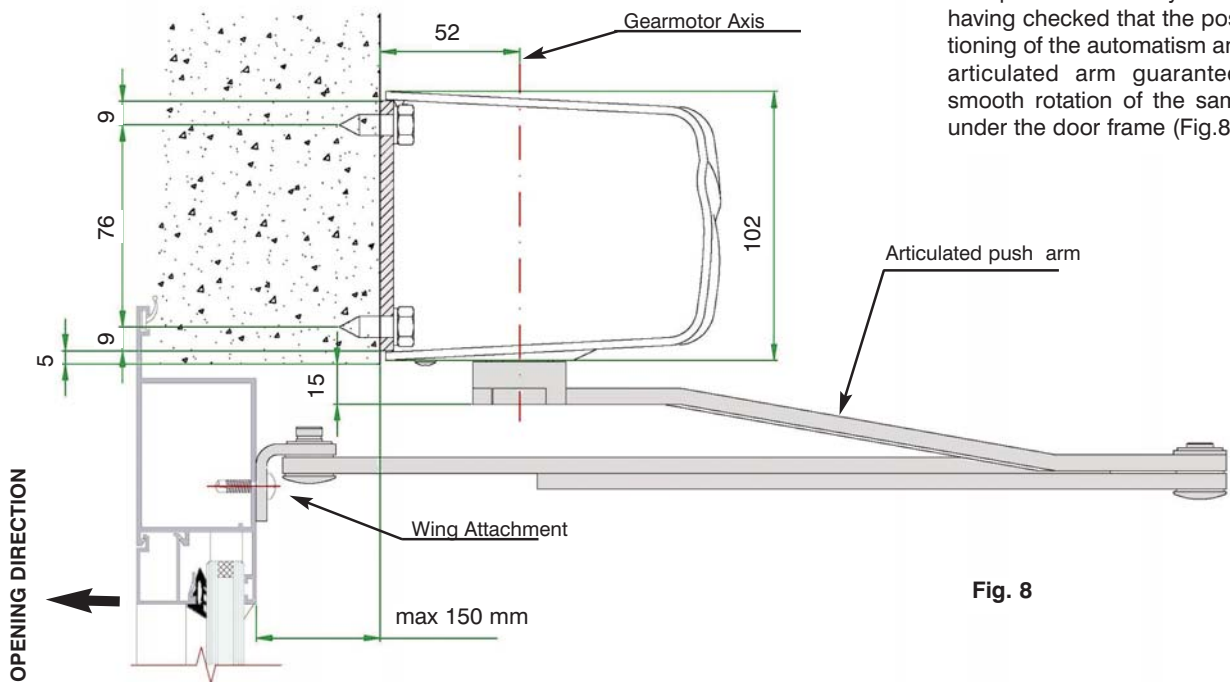
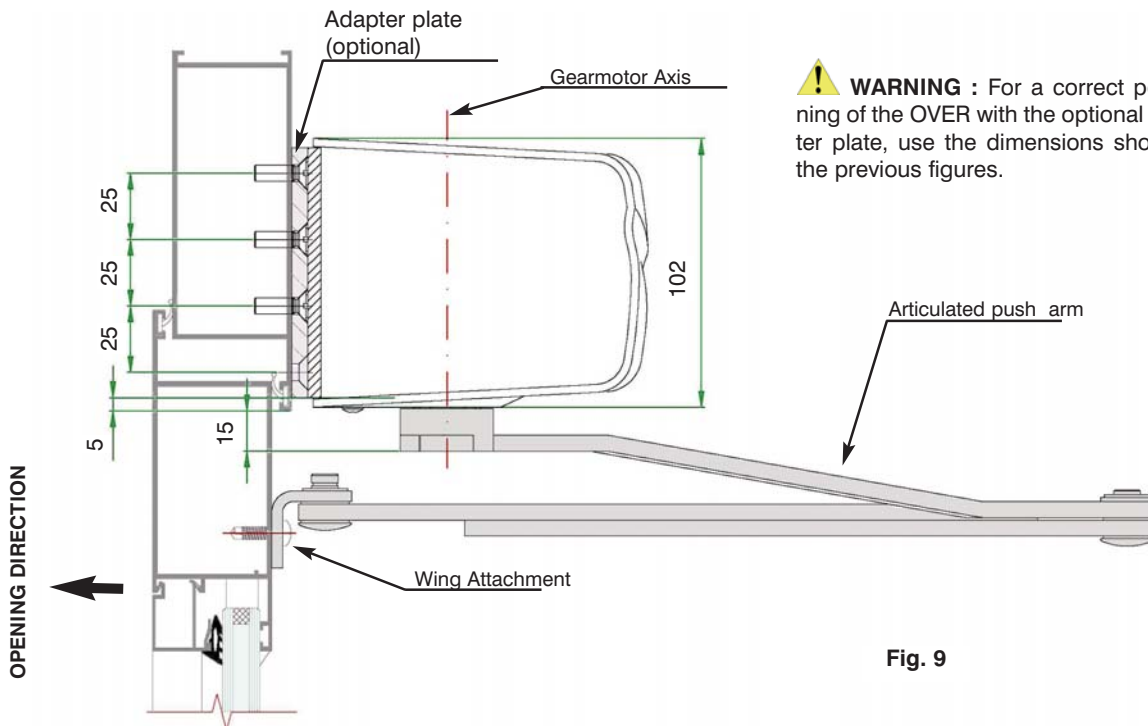

Fig. 8

Installation Instruction

Use of adapter plate (optional)

If one or more fastening points of the OVER plate are unusable for firmly anchoring the automatism to the fixed part, use the optional adapter plate.



WARNING : For a correct positioning of the OVER with the optional adapter plate, use the dimensions shown in the previous figures.

Fig. 9

Installation of the guide and rigid pull arm

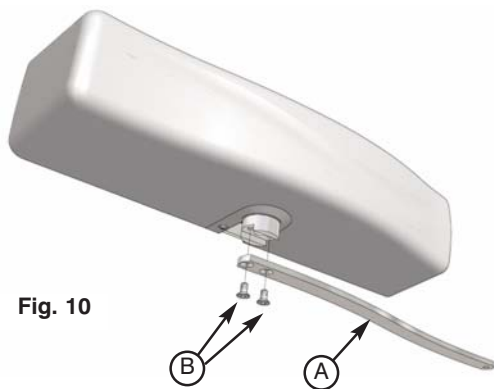

Fig. 10

Insert the bracket of the arm (Fig.10 Part A) in the appropriate seat on the gearmotor and fix it using the two countersunk-head screws provided (Fig.10 Part B).

Access the fastening compartment of the guide (Fig.11 Part A) by removing the cover (Fig.11 Part B). Make at least 4 holes corresponding to the "V" impression on the guide profile. Use the holes to fix the guide to the frame using the appropriate screws (Fig.11 Part C). Insert the cylindrical slide (Fig.11 Part D), complete with the relative spindle, inside the guide and distribute a uniform layer of grease over the sliding zone.

Then, after finishing the installation of the rigid arm (Fig.11 Part E), screw the threaded shaft, inserted in the cylindrical slide, into the hole prepared on the end of the rigid arm. Close the guide with the caps (Fig.11 Part F) and the screws provided (Fig.11 Part G).

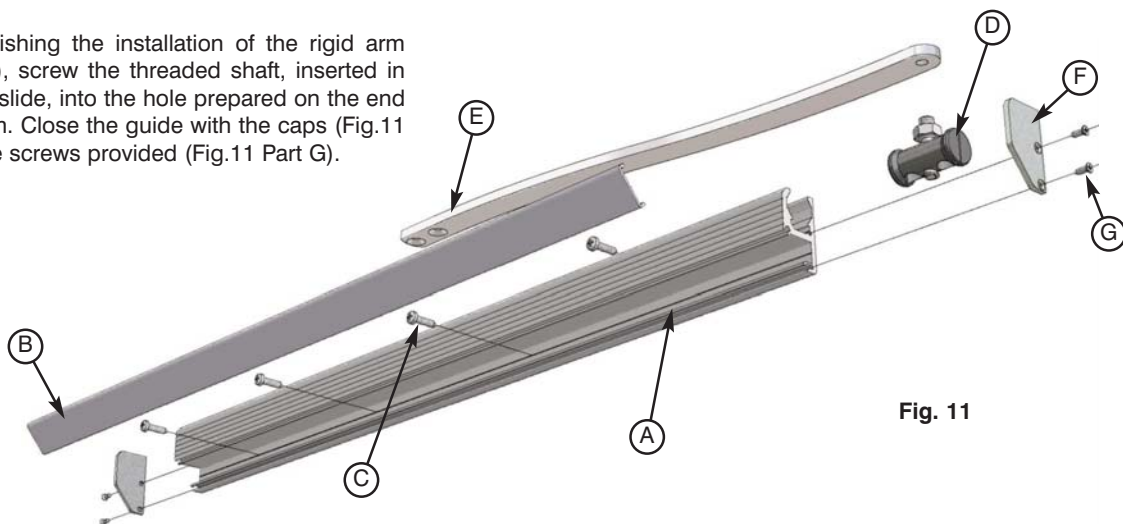

Fig. 11

Assembly of the articulated push arm

! WARNING : The articulated arm is NOT symmetric. Depending on the opening direction (right-hand or left-hand), position the brackets of the arm and the bushings as indicated in the following figures.

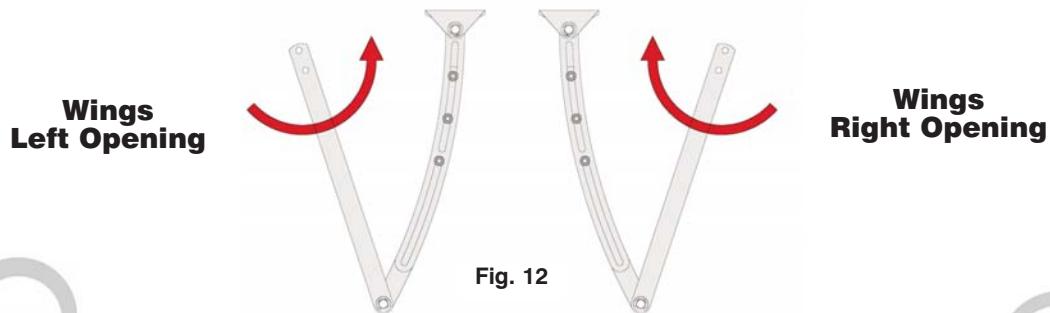

Fig. 12

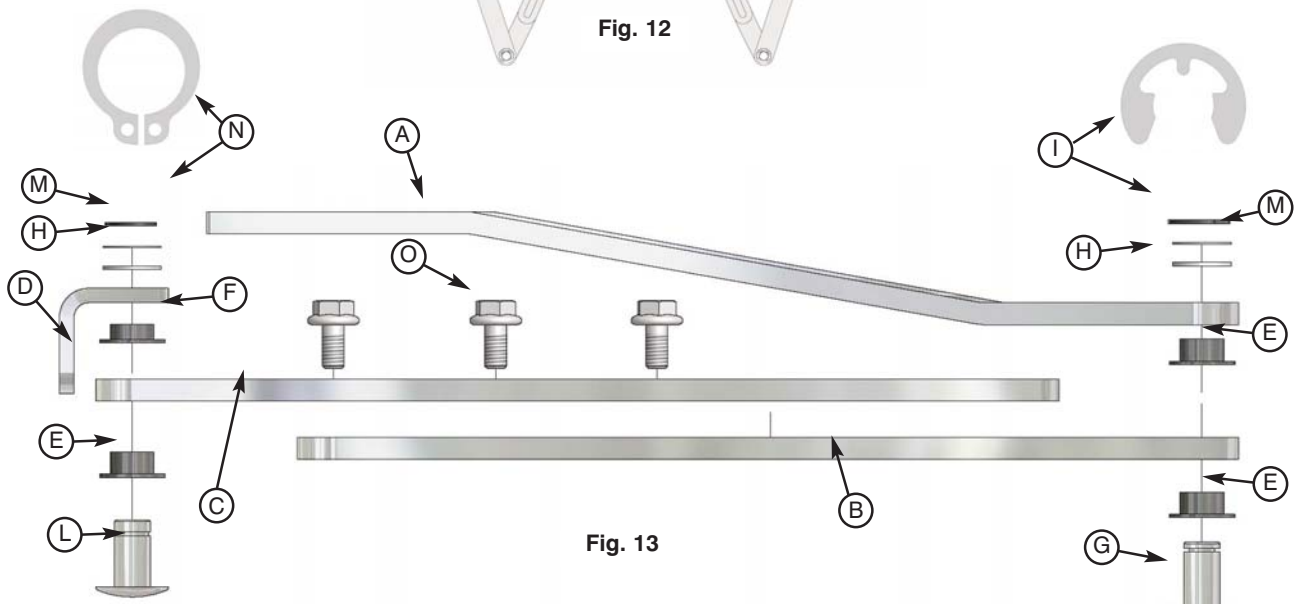

Fig. 13

Insert the 3 appropriate plastic bushings (E) into the articulated arm brackets (Fig.13 Parts A, B and C) and the plastic bushing (F) into the wing attachment bracket (D).

Insert the pin with the deep quarry (G) into the brackets (A) and (B) assembled previously, place a 1mm-thick shim (H) in between and a 0.5mm thick shim (M) in between and block with a seeger (I).

Insert the pin with the lower quarry (L) into the brackets (C) and (D) assembled previously, place a 1mm-thick shim (H) and a 0.5mm thick shim (M) in between and block with a seeger (N).

Block the preassembled parts using the three screws provided (O).

! WARNING : Carefully check that the seegers are inserted perfectly in the respective grooves.

Insert the bracket of the arm (Fig.13 part A) in the appropriate seat on the gearmotor and fix it using the two countersunk-head screws provided.

Carefully check that the upper part of the articulated arm rotates easily under the frame of the wing (Fig. 7, 8 and 9)

Drill the frame at the positions indicated in Fig.7 and fix the wing attachment of the articulated arm to the frame using the appropriate screws. Close the wing, loosen the fastening screws on the adjustment slots and then, lengthening the extendable part of the arm, reproduce the exact geometry shown in Fig.12.

Fix the adjustment by firmly tightening the clamp screws on the extendable part of the arm so as to use the prepared holes separated by the largest distance.

! WARNING : Check that when the door is completely open, the angle formed by the articulated arm does not exceed 140°. Fig. 14

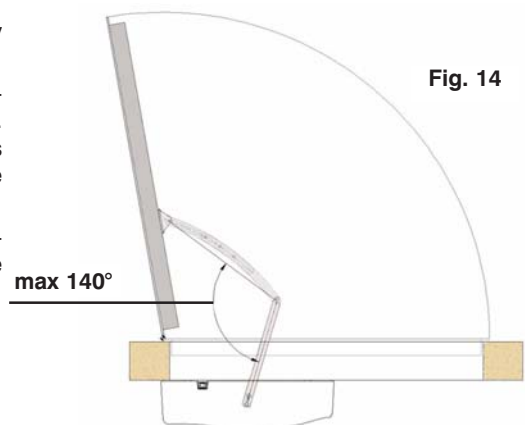

Fig. 14

Adjustment of the Stop

Open the wing to the desired opening limit, then position the rubberized stop on the floor and tighten the screw on the stop.

⚠ WARNING : The max. allowed opening angle is 100°.

Battery connections

Connect the battery wiring to the proper clamp on the electronic board

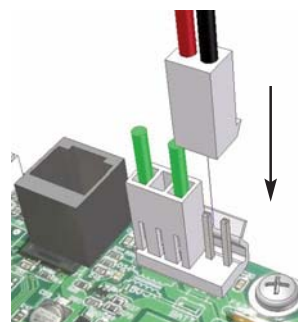

Fig. 15

Final operations

Before starting the automatism, check and perform the following:

- Accurately remove and dust or shavings
- Ensure the proper fixing of the automatism on the wall
- Check correct tightening
- Check that the wires are fixed and that no wire pass near the carriage sliding area.
- Check that the arm is solidly fixed to the wing and that it is equipped with the appropriate stop to limit the max opening angle to 100°.

Power connections

⚠ WARNING : Before performing the following operations make sure the mains are disconnected. Before powering the equipment, perform the controls foreseen in paragraph “Start up”.

Place the power cord in the automatism paying careful attention not to damage the cord against any metallic edges. Connect mains and grounding wires on the terminal board (Fig. 16)

⚠ WARNING : Never invert the power wire with the grounding wire.

Power must be isolatable from the general panel with a bipolar switch with minimum contact opening equal to 3 mm. (not supplied).

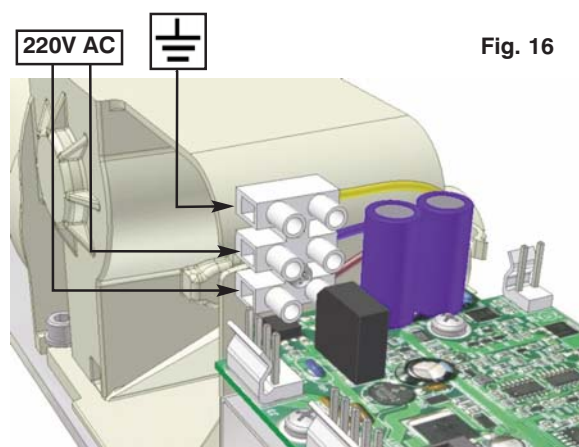

Fig. 16

Electrical connections

⚠ WARNING : All board or peripheral connections on the terminal board must be performed with the power disconnected to prevent irreparable damage to the electronic equipment.

⚠ WARNING : Any repairs or replacements must be performed by professionally qualified personnel and original spare parts must be used in repairs.

Number Wing Selection



S3 ON
Double-wing operation.

⚠ This option should be selected only in the case of two OVER automatism connected together for the opening of a two-wing entrance.



S3 OFF (DEFAULT)
Single-wing operation.

Single wing Multislave selection



S1 OFF
S2 OFF
S3 OFF
Single setting wing NO Multislave (DEFAULT)

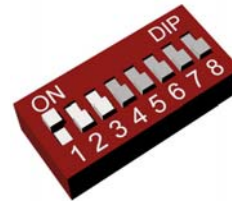

S1 ON
S2 OFF
S3 OFF
Single setting wing Multislave (address 1)

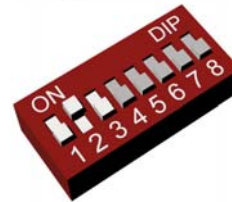

S1 OFF
S2 ON
S3 OFF
Single setting wing Multislave (address 2)

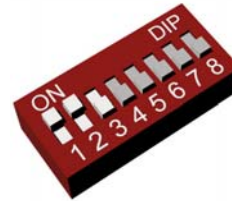

S1 ON
S2 ON
S3 OFF
Single setting wing Multislave (address 3)

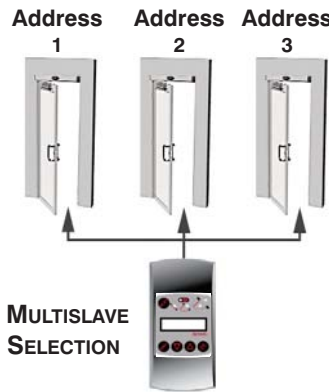

A single selector can be connected and extended to several OVER automatism using two different operation logics:

- **DEFAULT:** the selector acts on all the automatism connected to it without any distinction. For example, if the selector is used to set the Stop Open logic, all the automatism connected to it will work with the Stop Open logic.

- **MULTISLAVE:** with this logic up to 3 automatism can be connected, each identified with a different address to be set as indicated below. The selector can act on each of the three automatism in a completely independent manner.

⚠ The Multislave logic is NOT available for double OVER.

Double wing Master - Slave selection

⚠ In the double OVER, it is necessary to set a Master card and a Slave card. The two cards must NEVER be set both as Master or both as Slave

Synchronised door motion



S1 ON
S2 OFF
S3 ON
Enter double Master door with synchronised door motion.

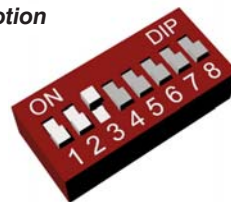

S1 OFF
S2 OFF
S3 ON
Enter double Slave door with synchronised door motion.

Asynchronous door motion



S1 ON
S2 ON
S3 ON
Enter double Master door.
If asynchronous it is the first to open and the last to close.

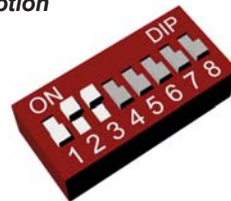

S1 OFF
S2 ON
S3 ON
Enter double Slave door.
If asynchronous it is the last to open and the first to close.

"Low Power" mode Selection

The OVER operation can be set in "low power" mode, which provides for reduced operating speeds and accelerations.



S4 ON
"low power" mode



S4 OFF (DEFAULT)
Normal mode

First Input Mode Selection

OVER can be connected to a closing device such as an electronic key, key selector, transponder, etc. Using the dip switch S5, the signal can be controlled in bistable or monostable mode with an activation time of about 500msec.



S5 ON
First input mode
Mono-stable

Automatism
Operation

Closing device
readings

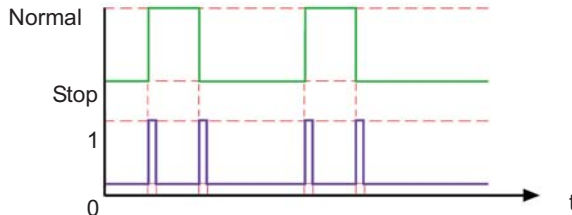

S5 OFF (DEFAULT)
First input mode
Bi-stable

Automatism
Operation

Closing device
readings

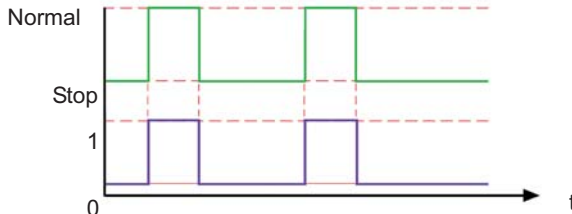

Antipanic mode Selection



S6 ON
Antipanic mode active.
In the event of power failure, the equipment moves the doors to the "Stop open" position, and stays in this condition until power returns or a new logic is selected using the multi-logic selector.



S6 OFF (DEFAULT)
Antipanic mode disabled.
In the event of power failure the equipment continues working powered by the battery.

Electric Lock Operation Selection



S7 ON
Electric Lock active
The electric lock is excited for a few moments whilst the door is opening, the door reverses a few millimetres before opening to allow the release the electric lock. Whilst the door is closing, it accelerates and then undergoes a thrust during the last few millimetres to rearm the lock.
As per default setting, the impulse timing of the electric lock is 120ms, but it is changeable using the selector KIBO PRO.



S7 OFF (DEFAULT)
Electric Lock disabled

! WARNING Before adjusting the impulse value, be sure about the compatibility with the electric lock installed
In case of wrong setting, the operation of the electric lock is compromised

Logic right / left opening sense



S8 ON
Wing Left Opening rigid pull arm

Wing Right Opening articulated push arm



S8 OFF (DEFAULT)
Wing Right Opening rigid pull arm

Wing Left Opening articulated push arm

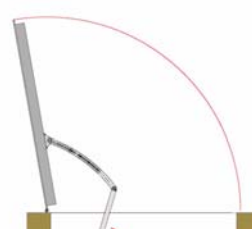
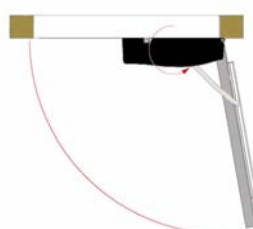
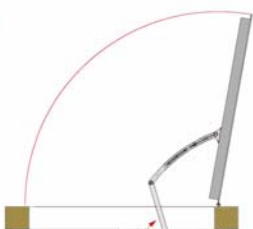
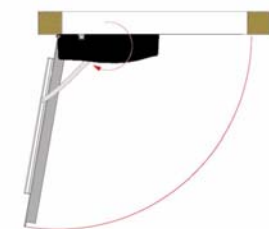

Wing Left Opening rigid pull arm

Wing Right Opening articulated push arm

Wing Right Opening rigid pull arm

Wing Left Opening articulated push arm

Type of arm selection

In order to optimize the operation of the automatism, it is necessary to set the jumper according to the following diagram:



OVER Electronic Board

The meanings of the main electronic board components are listed in Fig. 17 :

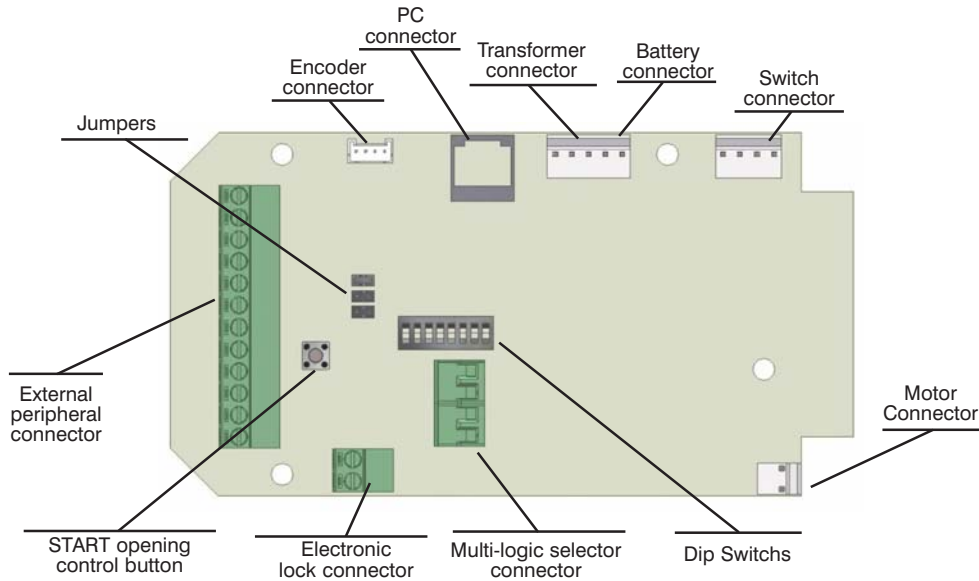

Fig. 17

Connections

Multi-logic selector connector

Use the four conductors in the shielded wire for connections, observing the correspondences indicated by the markings on the terminal board and multi-logic selector.

Do not connect the shield of the wire used.

For further information on multi-logic selector use, see the instructions for use.

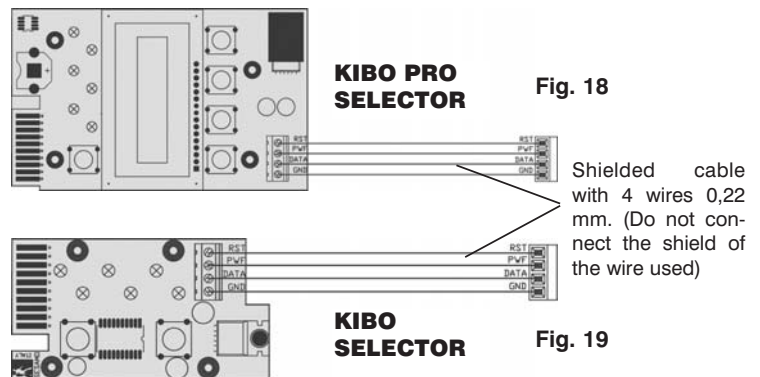

Fig. 18

Fig. 19

External peripheral power connector – 12 Vdc 2,5W max (200mA)

Real power value may vary from 12 Vdc \pm 10 % depending on the resistive load situations connected to these terminals.

Terminal **OUT / 12VDC** : POSITIVE (+)

Terminal **COM** : NEGATIVE (-)

⚠ WARNING

Do not invert power polarity. When the green led D33 is on it indicates normal voltage presence 12V. If off check:

- For mains and/or battery voltage

Installation Instruction

External peripheral connector

The electrical signal from external peripherals can be varied through the advanced selector or PC connection: from normally closed to normally open and vice versa. See the advanced selector used manual for further details.

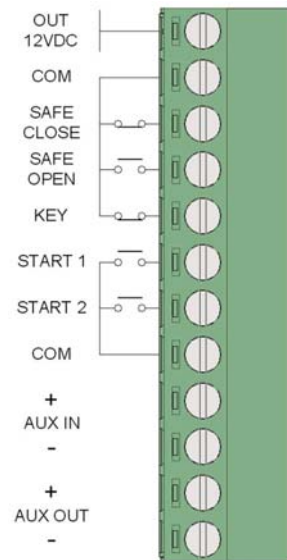

Fig. 20

SIGNAL	TYPE*	DESCRIPTION	FUNCTION
COM		Common electrical signal.	
SAFE CLOSE	NC	Signal for the connection of an external photocell or safety control device for wing closing	If the door is closing and the contact opens, the unit sends an immediate motion inversion command. Closing will only recommence after the contact closes. The signal must be short circuited with COM if not devices (internal or external) are connected.
AUX IN	NA	Auxiliary input signal. Auxiliary devices can be connected to this signal. It is normally used for inter lock functions.	When used as an auxiliary signal the function logic can be personalised according to customer requests. When used as inter lock logic, closing this signal inhibits door functions that will not open even with open signal presence.
AUX OUT		Auxiliary output signal, PNP transistor type for particular door condition signals (reset, open, closed, etc).	According to the type chosen signal, the output becomes active (12Vdc and led on) when the door is in the set condition (Reset, open, closed, etc). See the KIBO PRO selector manual for further details.
SAFE OPEN	NA	Signal for the connection of sensors for protection during wing opening.	If the door is opening and the contact closes, the unit sends an immediate movement stop command. Opening will only continue after this signal is deactivated.
KEY	NC	Lock signal. Closure devices can be connected such as electronic key, key selector, transponder, etc. The signal can be controlled in bi or mono-stable mode with an activation time equal to about 500 msec.	If the signal opens the unit sends a complete wing closure command (from any position) From this moment until the signal is closed the door stays in this position and no external peripheral is detected (including multi-logic selectors). As soon as the signal closes the door opens permitting access. The signal must be short circuited with COM if no devices are connected.
START 1	NA	Opening signal. Wing opening devices can be connected.	Closing this signals causes the wings to open. This signal is only monitored in 2 Radar logic.
START 2	NA	Opening signal. Wing opening devices can be connected.	Closing this signals causes the Door to open. This signal is monitored in both 2 Radar and 1 Radar logic.

* NA = Normally open NC = Normally closed

Connector for PC - unit connections

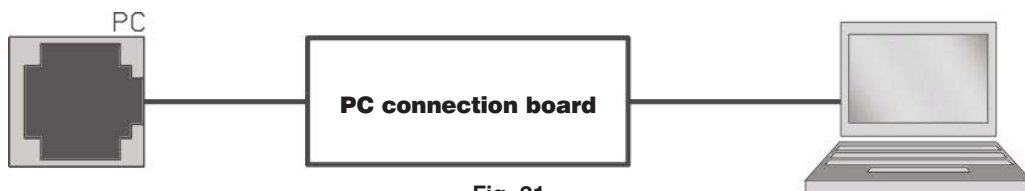

Fig. 21

A PC connection board (optional) is required to connect the OVER unit to a Personal Computer.

The following is possible with OVERWARE software:

- Advanced adjustments of some operating parameters
- Diagnostics and advanced information on unit status
- Microprocessor programming

LED Functions

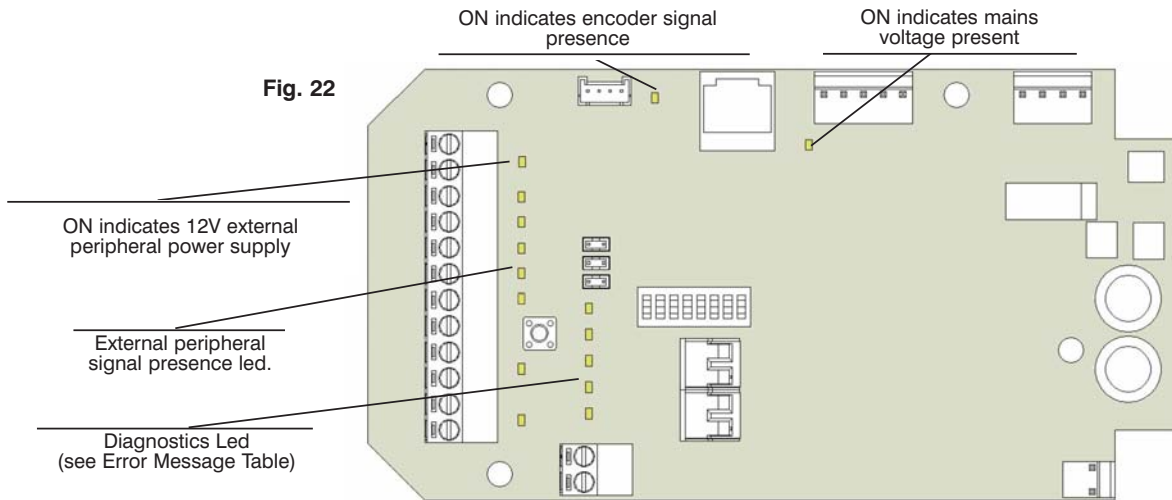

Jumpers

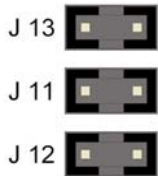





Jumper	ON	OFF (Default)
J13	Articulated arm	Rigid pull arm
J11	Set cycle operations	Normal operation
J12	-	-

! Set properly the jumper J13, look at the arm typology paragraph

Setting parameter adjustment

PARAMETERS	DEFAULT VALUE	ADJUSTMENT GAP		ADJUSTMENT VIA		
				KIBO PRO SELECTOR	PC	
STANDARD	Opening speed (°/s)	50	10	50	•	•
	Closing speed (°/s)	30	10	50	•	•
	Pause time (sec)	0	0	120	•	•
	Anti-crush Opening	9	1	9	•	•
	Anti-crush Closing	5	1	9	•	•
ADVANCED	Approach speed (°/s)	5	5	10		•
	Reset speed (°/s)	12	10	20		•
	Recovery speed (°/s)	20	10	30		•
	Normal acceleration (°/s ²)	150	50	200		•
	Normal deceleration (°/s ²)	40	20	60		•
	Reset acceleration (°/s ²)	100	20	100		•
	Reverse acceleration (°/s ²)	100	50	200		•
	Approach Closing (°)	20	20	40		•
	Approach Opening (°)	15	15	30		•
	Anti-draught level	0	0	9		•
	Push & Go activation	1	0	9		•
	Asynchronous opening of double doors	3	1	9		•
	Asynchronous closing of double doors	5	1	9		•
	Safety exclusion opening (%)	0	0	99	•	•
	Last battery-operated manoeuvre	stop open	stop open	stop close	•	•
	Auto Reset	yes	yes	NO	•	•
	Logic after Reset	2 radar	2 radar, 1 radar, stop open, stop close		•	•
Activation timing of the electric lock (10 ⁻¹ sec)	1	0	20	•		
SAFE OPEN operation	stop motion	stop motion	slow motion	•	•	

Start Up - Operating logic

Operations	Description	
 WARNING	If no optional operation lock device is installed, make sure the KEY input is short circuited with the COM input. Otherwise the equipment cannot be started. If no safe close device is installed, make sure the SAFE CLOSE input is short circuited with the COM input. Otherwise the equipment cannot be started.	
Power	Position wings ~20 cm from total closure. Turn the power switch to 1 to power the equipment.	
 WARNING	In the event of power failure the equipment can not be started and the Reset operation is not available. The battery pack ensures the proper use only when the power failure happens during the normal operation of the equipment.	
Reset and auto-setting of ends-of-stroke	The device is switched on and the reset phase checked. The device completely opens and completely closes the door at low speed (reset speed). If an obstacle prevents the door from completing its entire stroke, the device will signal that there is an initialization error (AV=intermittent and L3=On) if the stroke is less than a preset limit (around 70-80°) and performs another reset after 10 seconds. After the third failed reset, the device stops functioning as a malfunction. The reset continues even if the safety sensor (Safe Open) detects an obstacle. If the IR photocell sends a signal that an obstacle has been detected whilst the door is closing, the door will stop moving for the entire duration of the signal.	
 WARNING	Multi-logic selector not installed: when the equipment finishes limit reset it is ready to work in 2 RADAR logic.	
 WARNING	Multi-logic selector installed: when the equipment finishes limit reset it is ready to work and is positioned in the "STOP CLOSED" logic.	
 WARNING	At the end of reset the equipment is ready for use; check correct sensor operations for opening command and safety control. Also check anti-crushing sensitivity; if the value requires increasing and decreasing, see the advanced selector manual. To test automatism operations without connections to the open command device use the START button on the unit (see Fig. 17)	
Standard manoeuvre	The device opens and closes the door accelerating and decelerating in accordance with the opening and closing speed limits, which will be reached at low speed.	
Push&Go	An initial push on a closed door will cause it to open. The activation value can be adjusted using OVERWARE	
Reverse function (radar 1 and 2)	If the radar detects an obstacle whilst the door is closing, it must suddenly reverse motion opening completely at normal speed and closing at normal speed.	
Reverse function (IR)	After the IR detects an obstacle whilst the door is closing, it must suddenly reverse motion opening completely at normal speed and closing at normal speed.	
Safety sensor function whilst opening (Safe Open)	If the safety sensor (Safe Open) detects an obstacle whilst the door is opening, it will immediately stop the motion of the door. If the sensor no longer detects an obstacle, the door will continue to open at low speed and then close at normal speed. The door complete an opening cycle at reduced speed after 30 seconds from the continuous activation of the safe open. Detection of obstacles whilst the door is closing does not cause the system to react.	
Safety sensor exclusion angle whilst opening (Safe Open)	If the door opens near a wall (in a corridor, for example), an value must be entered so that the sensor does not detect the wall as an obstacle (% total limit switch). Default value = 0. Parameter can be adjusted using KIBO PRO or OVERWARE.	
Safety sensor function whilst closing (Safe Close)	If the safety sensor (Safe Close) detects an obstacle whilst the door is closing, it will immediately stop and reverse the motion of the door opening it completely at low speed and then closing it at normal speed. Detection of obstacles whilst the door is opening does not cause the system to react.	
Operating logic can be entered using the KIBO, KIBO PRO, OVERWARE	1 radar	Exit-only radar: only the input START 2 of the electronic control card is monitored. A signal originating from a sensor connected to this input triggers the opening and consequent closing of the door wings. The electric locking system, if present, blocks the door wings every time that these reach the position of complete closure
	2 radar	Entry-exit radar : both the inputs START1 and START2 of the electronic control card are monitored. A signal originating from a sensor connected to one of these inputs triggers the opening and consequent closing of the door wings. The electric locking system, if present, never blocks the door wings.
	Stop Close	The automatism controls the complete closure of the door wings. In this logic the inputs START1 and START2 of the electronic control card are not monitored; if present, the electric locking system blocks the door wings.
	Stop Open	The automatism controls the complete opening of the door wings. In this logic the inputs START1 and START2 of the electronic control card are not monitored.
Single anti-crush safety function whilst opening	The door encounters an obstacle that stops its motion whilst it is opening. The device should stop the motion of the door for a few seconds and then open it completely at low speed and close it again at normal speed. The sensitivity value can be adjusted using the KIBO PRO and OVERWARE.	
Single anti-crush safety function whilst closing	The door encounters an obstacle that stops its motion whilst it is closing. The device should stop the motion of the door for a few seconds and then open it completely at low speed and close it again at low speed. The sensitivity value can be adjusted using the KIBO PRO and OVERWARE.	

Operazioni		Descrizione
Multiple anti-crush function whilst opening (with Autoreset after malfunction)	Near the closure (gap of around 0° to 25°)	The door encounters an obstacle that stops its motion whilst it is opening. The device should stop the motion of the door for a few seconds and then open it completely at low speed and close it again at normal speed. After detecting the third obstacle without being able to complete the manoeuvre (without completely opening the door), the device signals a malfunction (AV=intermittent and L1=On), stops for a few seconds whilst closing and then performs a new reset to set the ends-of-stroke. If the object remains in the movement area it will be detected as the end-of-stroke and the device will function with two new ends-of-stroke. If the obstacle is near the door frame, the device will signal an initialization error that the door opening is too small (AV=intermittent and L3=On). If the obstacle is later cleared, the device will function without an end-of-stroke whilst opening for another two cycles, after which it will signal an error (AV=intermittent) because it cannot find the end-of-stroke and will perform a new reset to set the ends-of-stroke.
	In the middle (various positions)	The door encounters an obstacle that stops its motion whilst it is opening. The device should stop the motion of the door for a few seconds and then open it completely at low speed and close it again at normal speed. After detecting the third obstacle without being able to complete the manoeuvre (without completely opening the door), the device signals a malfunction (AV=intermittent and L1=On), stops for a few seconds whilst closing and then performs a new reset to set the ends-of-stroke. If the object remains in the movement area it will be detected as the end-of-stroke and the device will function with two new ends-of-stroke. If the obstacle is later cleared, the device will function without an end-of-stroke whilst opening for another two cycles, after which it will signal an error (AV=intermittent) because it cannot find the end-of-stroke and will perform a new reset to set the ends-of-stroke.
	Near the opening (gap of around 70° to 90°)	The door encounters an obstacle that stops its motion whilst it is opening. The device should stop the motion of the door for a few seconds and then open it completely at low speed and close it again at normal speed. After detecting the third obstacle without being able to complete the manoeuvre (without completely opening the door), the device signals a malfunction (AV=intermittent and L1=On), stops for a few seconds whilst closing and then performs a new reset to set the ends-of-stroke. If the object remains in the movement area it will be detected as the end-of-stroke and the device will function with two new ends-of-stroke. If the obstacle is later cleared, the device will function without an end-of-stroke whilst opening for another two cycles, after which it will signal an error (AV=intermittent) because it cannot find the end-of-stroke and will perform a new reset to set the ends-of-stroke.
Multiple anti-crush function whilst closing (with Autoreset after malfunction)	Near the closure (gap of around 0° to 25°)	The door encounters an obstacle that stops its motion whilst it is closing. The device should stop the motion of the door for a few seconds and then open it completely at low speed and close it again at low speed. After detecting the third obstacle without being able to complete the manoeuvre (without completely closing the door), the device signals a malfunction (AV=intermittent and L1=On), stops for a few seconds whilst closing and then performs a new reset to set the ends-of-stroke. If the object remains in the movement area it will be detected as the end-of-stroke and the device will function with two new ends-of-stroke. If the obstacle is later cleared, the device will function without an end-of-stroke whilst opening for another two cycles, after which it will signal an error (AV=intermittent) because it cannot find the end-of-stroke and will perform a new reset to set the ends-of-stroke.
	In the middle (various positions)	The door encounters an obstacle that stops its motion whilst it is closing. The device should stop the motion of the door for a few seconds and then open it completely at low speed and close it again at low speed. After detecting the third obstacle without being able to complete the manoeuvre (without completely closing the door), the device signals a malfunction (AV=intermittent and L1=On), stops for a few seconds whilst closing and then performs a new reset to set the ends-of-stroke. If the object remains in the movement area it will be detected as the end-of-stroke and the device will function with two new ends-of-stroke. If the obstacle is near the door frame, the device will signal an initialization error that the door opening is too small (AV=intermittent and L3=On). If the obstacle is later cleared, the device will function without an end-of-stroke whilst opening for another two cycles, after which it will signal an error (AV=intermittent) because it cannot find the end-of-stroke and will perform a new reset to set the ends-of-stroke.
	Near the opening (gap of around 70° to 90°)	The door encounters an obstacle that stops its motion whilst it is closing. The device should stop the motion of the door for a few seconds and then open it completely at low speed and close it again at low speed. After detecting the third obstacle without being able to complete the manoeuvre (without completely closing the door), the device signals a malfunction (AV=intermittent and L1=On), stops for a few seconds whilst closing and then performs a new reset to set the ends-of-stroke. If the object remains in the movement area it will be detected as the end-of-stroke and the device will function with two new ends-of-stroke. If the obstacle is near the door frame, the device will signal an initialization error that the door opening is too small (AV=intermittent and L3=On). If the obstacle is later cleared, the device will function without an end-of-stroke whilst opening for another two cycles, after which it will signal an error (AV=intermittent) because it cannot find the end-of-stroke and will perform a new reset to set the ends-of-stroke.

Error Message Table

DESCRIPTION	N.	LED					WHAT TO DO
		AV	OC	L1	L2	L3	
Initialization error	1	INT	OFF	OFF	OFF	ON	An error occurred during initialisation, in particular, the measured opening quota is too low. Check the encoder, the connection between the encoder and mother boards. Make sure the transit area is free of obstacles. In the event of electronic lock, check correct operations.
Door blocked error	2	INT	OFF	OFF	ON	OFF	The door cannot open. Make sure there are no obstacles in the transit area and that there are no locks (electric or manual) that block the door.
Anti-crushing error	3	INT	OFF	ON	OFF	OFF	After three closing and anti-crushing detection attempts. Make sure there are no obstacles in the transit area. Make sure that the anti-crushing sensitivity in opening is not too low. Check the encoder, the connection between the encoder and mother boards.
Inversion error	4	INT	OFF	ON	OFF	ON	An inversion error of the movement between the encoder and motor was detected.
Overcurrent error	5	INT	ON	ON	ON	OFF	Motor overload detected. Make sure there are no short circuits on the motor power cord. Check the motor and replace if necessary.
Encoder error	6	INT	OFF	ON	ON	ON	Encoder malfunction detected. Check the encoder, the connection between the encoder and mother boards.

BL. = Blinking

Double OVER connection and use

Define the Master door (see Set Dip-Switch paragraph) before performing the connections.

! It will not be possible to determine the Master or Slave door after completing the wiring.

Both devices should be connected to the same power supply branch with no switches or fuses between them.

The SAFE CLOSE, KEY, START 1 and START 2 peripherals, if any, should be connected to the Master door.

The safety sensors (Safe Open) should be connected and controlled separately on both circuit cards.

The two terminals of the selector should be connected to ensure that both OVER circuit cards communicate with each other and that both devices function properly. (**Fig. 23**)

The selector (optional) is connected to the Master card only. Any parameters that need to be changed will be the same for both cards.

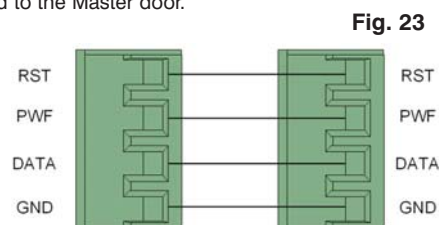

Double doors should be moved in asynchronously (see Set Dip-Switch paragraph) if there is a central jamb between them. The default settings are 3 (opening) and 5 (closing), and can be modified using OVERWARE.

The doors will only start to close when both are wide open. If one door opens completely before the other one, it will wait until the latter is completely open.

Both doors reverse at the same time (START 1 or 2, SAFE CLOSE, anti-crush safety device, etc.).

The electric lock functions can be entered on both circuit cards in exactly the same way as with single devices by selecting Dip S7.

The Push&Go function can be activated on both devices in exactly the same way as with single devices. If it is detected that one of the devices is trying to open a door, this will cause both doors to open.

The anti-crush safety devices and obstacle detection functions are controlled separately and independently by both cards.

If one card detects an anti-crush device whilst closing, it will stop the motion of both doors and open them completely at low speed.

If one card detects an anti-crush device whilst opening, it will stop the motion of the door involved and open it completely at low speed. The other door, which will have opened completely in the meantime, will wait for the door involved before proceeding to close.

! The parameters that can be modified with OVERWARE are separate on each card. If the motion parameters are modified, the same values must be set on both cards to prevent malfunctions.

Inter lock connection and use

The OVER unit is set to work in inter lock mode through connections to an electronic unit of the same family. In inter lock mode one door can only open if the other is not moving, that is, if not in the movement phase. To inter lock two automatisms proceed as follows (**Fig. 24**):

- connect the terminal **AUX IN +** of unit A to the terminal **AUX OUT +** of unit B
- connect the terminal **AUX IN -** of unit A to the terminal **AUX OUT -** of unit B
- connect the terminal **AUX OUT +** of unit A to the terminal **AUX IN +** of unit B
- connect the terminal **AUX OUT -** of unit A to the terminal **AUX IN -** of unit B

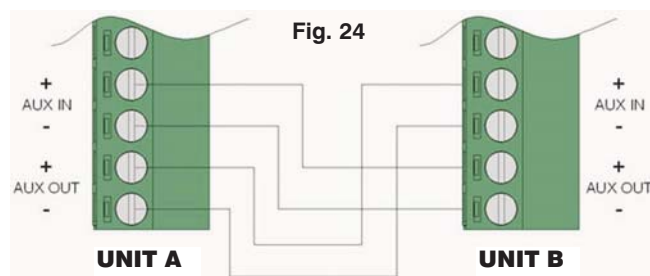

Use 4 x 0.22 shielded wire for connections and do not connect the shield.

When open requests come from the both sensors on both doors an opening priority needs to be set; to do this, set one door as MASTER and the other as SLAVE.

When simultaneous signals occur, the MASTER door will open.

! **WARNING:** The interblock function is NOT available for double OVER

Delivery modality

Reassemble the cover by screwing on the two appropriate screws.

Hand the guarantee and test certificate over filled according to the instructions shown in the certificate.

Hand the technical documentations over to the client.

OVER



Aprimatic S.p.A.

Zona Industriale Fossatone

40060 Villa Fontana • Medicina • Bologna (ITALY)

Tel: +39 051 6960711 • Fax: +39 051 6960722

www.aprimatic.it • E-mail: info@aprimatic.com